

Charging Arrangements for New Connections Services 2021/2022

Affinity Water Limited



Affinity Water Limited

Registered in England (company number 2546950)

Registered office: Tamblin Way, Hatfield, Hertfordshire, AL10 9EZ

Contents

1. Introduction	3
2. Our water supply area.....	6
3. Definitions and Interpretation	7
4. Surface types.....	9
5. Pre-development & Point of Connection enquiries	10
6. Charges - Self-Lay Water Mains	11
7. Charges - Self-Lay Service Connections	15
8. Requisition Charges (New mains).....	17
9. Connection Charges	24
10. Developer Diversion Charges	29
11. Traffic management	32
12. Out of hours working	33
13. Miscellaneous charges	34
14. Payment Terms	36
15. Transitional Arrangements.....	37
16. Infrastructure Charges & Associated Credits	38
17. New Appointees	42
18. Worked Examples	43
19. Contact information & Redress.....	53

1. INTRODUCTION

1.1 GENERAL

- (1) These charging arrangements are made by Affinity Water Limited pursuant to Ofwat's charging rules.
- (2) Subject to the transitional arrangements set out in these charging arrangements they have effect in relation to charges imposed on or after 1 April 2018 by Affinity Water Limited under or pursuant to the following provisions of the 1991 Act:
 - a. section 42(2)(a) (provision of new water main);
 - b. section 45(6) (connections with water main);
 - c. section 46(7)(b) (ancillary works for domestic connection);
 - d. section 185(5) (moving of pipes etc); and
 - e. an agreement made under section 51A (adoption agreement).
- (3) These charging arrangements are supplementary to statutory provisions that apply to undertakers under any enactment, or instrument made thereunder (including the conditions of their appointments). In the event of any conflict between these charging arrangements and any statutory provision, the latter shall prevail.
- (4) These charging arrangements should be read and construed in conjunction with the 1991 Act (and any regulations made thereunder) and our Instrument of Appointment. In the event of any conflict or inconsistency with these charging arrangements, the provisions of the 1991 Act (and any regulations made thereunder) or, as the case may be, our Instrument of Appointment will prevail.
- (5) In the event of any conflict or inconsistency with these charging arrangements, the provisions of the water sector guidance and / or the code for adoption agreements as the case may be will prevail.
- (6) If any court or competent authority finds that any provision of these charging arrangements (or part of any provision) is invalid, illegal or unenforceable, that provision or part-provision is, to the extent required, to be deemed to be deleted, and the validity and enforceability of the other provisions of these charging arrangements is not to be affected.
- (7) If any invalid, unenforceable or illegal provision of these charging arrangements would be valid, enforceable and legal if some part of it were deleted, the provision shall apply with the minimum modification necessary to make it legal, valid and enforceable.
- (8) These charging arrangements do not apply in relation to:
 - a. any request for a supply of water for non-domestic purposes to which section 55 of the 1991 Act applies;
 - b. any request made by a water supply licensee for the connection of premises to our supply system, or other steps in respect of that system, to which section 66A of the 1991 Act applies; or
 - c. any charges that may be imposed by Affinity Water Limited under an agreement to provide one or more water undertakers with a supply of water in bulk.

- (9) Where premises within our water supply area are to be connected to our supply system in contemplation of being supplied by a water supply licensee pursuant to a retail authorisation, these charging arrangements shall be a charges scheme made by us under Section 143 of the Act setting our charges and charging policies in respect of the costs of providing and / or facilitating the infrastructure necessary to connect those premises to our supply system.
- (10) The charges set by these charging arrangements apply solely to works and services provided in the charging year and where any works and/or services have not been completed at the end of the charging year the charges applicable to those works or services shall be those set by the charging arrangements for the charging year in which those works and / or services are provided.
- (11) For 2021/22 the overall change in our charges does not typically exceed 10% and we therefore consider that the broad balance of charges is unchanged from 2020/21.

1.2 SELF-LAY PROVIDERS

- (1) If your development requires new water mains and service connections, you may choose an accredited contractor to do the contestable work rather than requesting us to do it. This is known as "Self-Lay".
- (2) You may prefer to use a self-lay provider (SLP) because they may be able to provide a multi-utility option, which may be a more cost-effective solution and provide greater flexibility to meet construction programmes.
- (3) Before a self-lay provider can carry out the work, they must be approved by us. This is achieved by the self-lay provider being accredited under the Water Industry Registration Scheme (WIRS), which is maintained by Lloyd's Register. A link to the register is provided below.

<https://www.lr.org/en/utilities/water-industry-registration-scheme-wirs-wirsae/search>

- (4) We will enter into an agreement with you and your chosen self-lay provider to take over responsibility for and ownership of the self-laid pipes provided they meet our requirements. We will provide parts of the service which are non-contestable and will work with your chosen self-lay provider to co-ordinate the works.
- (5) If you require further details or wish to apply for a self-lay scheme, please use the link to our website and select the Self-Lay option for further details:

<https://www.affinitywater.co.uk/developing/self-lay-providers>

1.3 NEW APPOINTMENTS AND VARIATIONS (NAVS)

- (1) A new appointment is made where a limited company is appointed by Ofwat to provide water and/or sewerage services for a specific geographic area.
- (2) A variation is where an existing appointed company (an "appointee") asks Ofwat to vary its appointment so it can extend the areas it provides services to. A new appointee has the same duties and responsibilities as the previous statutory water company, including providing water mains and service connections to support new developments.
- (3) New appointments and variations therefore involve one company replacing another as the appointee for a specific geographic area. Where the company appointed does not have access to its own water supplies, it may ask us to provide a bulk supply of water to connect to the water mains infrastructure within its water supply area.
- (4) A new appointment or variation may be made in relation to a site if it meets one of the following criteria:

- a. the unserved criterion: The area does not contain any premises that receive water services from us; or
- b. the consent criterion: We agree to the site being supplied with water by another appointee; or
- c. the large user criterion: where an individual premise uses (or is likely to use) at least 50 megalitres of water a year.

2. OUR WATER SUPPLY AREA

- (1) Our water supply area is defined in our Instrument of Appointment and comprises three discrete regions in the south east of England shown on the map below.



- (2) Sewerage services in our Central Region are provided by Thames Water Utilities Limited (“Thames Water”) and Anglian Water Services Limited (“Anglian Water”). Sewerage services in our East Region are provided by Anglian Water while sewerage services in our Southeast Region are provided by Southern Water Services Limited (“Southern Water”).
- (3) Enquiries about providing your development with a connection to a public sewer should be made to the relevant sewerage undertaker.

Sewerage Provider	Affinity Water Area Served	Contact Number
Anglian Water	Central Region & East Region	0345 606 6087
Thames Water	Central Region	0800 009 3921
Southern Water	South East Region	0330 303 0119

3. DEFINITIONS AND INTERPRETATION

- (1) If not defined to the contrary below, words and expressions used in these charging arrangements shall have the meanings given in the 1991 Act. References to the 1991 Act or to any other act or regulations shall include its or their amendment or replacement.

Term	Meaning
1991 Act	The Water Industry Act 1991 (as amended).
budget estimate	A high-level, indicative estimate in respect of our charges you are likely to incur for your water mains for your development.
charges scheme	A charges scheme under section 143 of the 1991 Act.
Charges scheme rules	The Charges Scheme Rules issued by the Water Services Regulation Authority under sections 143(6A) and 143B of the 1991 Act.
charging arrangements	This document which sets out the charges, income offsets and/or the methodologies for calculating those, applied by us in accordance with Ofwat's charging rules.
charging year	A year running from 1 April in a given year to 31 March in the following year.
code for adoption agreements	The code in respect of adoption agreements issued by Ofwat from time to time under Section 51CA of the 1991 Act.
communication pipe	Any part of a service pipe which an undertaker could be, or has been, required to lay under section 46 of the 1991 Act.
connection charges	The charges we will impose for work carried out by us in accordance with our duties (or rights) under section 45(1) (connection with water main) and section 46(1) (ancillary works for purposes of making a domestic connection) of the 1991 Act.
contestable work	Work or services that either we or persons other than us (e.g. self-lay providers) may do or provide.
design and construction standards	The design and construction standards published by us from time to time which shall be in accordance with any water sector guidance.
developer	Any person or business which is responsible for a development.
development	Premises on which there are buildings, or on which there will be buildings when proposals made by any person for the erection of any buildings are carried out, and which require connection with, and/or modification of, existing water infrastructure.
diversion charges	The charges we impose for work carried out by us to divert water mains and other apparatus in accordance with our duties (or rights) pursuant to section 185(5) of the 1991 Act.
fixed charges	Charges set for a given charging year which are fixed in amount or which are calculated by reference to a predetermined methodology set out in these charging arrangements, the application of which allows calculation at the outset of the total amount owing in that charging year in respect of the charges in question. Such charges are to be fixed for a charging year, as defined above.
income offset	"Income Offset" means a sum of money offset against Infrastructure Charges in recognition of revenue likely to be received by the relevant undertaker in future years for the provision of:

	Supplies of water to the premises connected to the new Water Main and “Income Offsetting” shall be construed accordingly.
Infrastructure Charges	The charges described in section 146(2) of the 1991 Act.
instrument of Appointment	The written instrument (as varied from time to time) appointing Affinity Water Limited as the water undertaker for the areas described and subject to the conditions set out in the instrument, under what is now Section 6 of the 1991 Act.
network reinforcement	Work other than site specific work, to provide or modify such other water mains and such tanks, service reservoirs and pumping stations as is necessary in consequence of the site specific installation or connection of water mains and service pipes pursuant to an agreement with, or a duty owed under the 1991 Act, including a requisition (under section 41(1)), under an agreement for adoption (under section 51A), under a section 66D agreement, pursuant to section 45(1) or in accordance with another duty imposed by the 1991 Act. It also includes the additional capacity in any earlier water main that falls to be used in consequence of the provision or connection of a new main.
non-contestable work	Work or services that we (or an agent acting on our behalf) can do or provide.
Ofwat	The Water Services Regulation Authority.
Ofwat’s charging rules	“New Connection Charging Rules” means the Charging Rules for New Connection Services (English Undertakers) issued by Ofwat under sections 51CD, 105ZF and 144ZA of the 1991 Act.
Phase	The phase of a development as may be set out in a planning permission granted by a local planning authority or identified in the developer’s construction plans.
cost advice	A document we issue to you setting out the charges payable by you or income offset payments payable by us in accordance with these charging arrangements for the scope of work set out in the document.
requisition charges	Charges imposed by us for work we carry out in accordance with the duties imposed on us by section 41(1) (provision of requisitioned water main) of the 1991 Act.
self-lay provider	A person carrying on the business of constructing water mains and/or service pipes for developments to be adopted by a water undertaker pursuant to an adoption agreement.
service pipe	So much of a pipe which is, or is to be, connected with a water main for supplying water from that main to any premises as: (a) is or is to be subject to water pressure from that main; or (b) would be so subject but for the closing of some valve, and includes part of any service pipe.
site specific	Work on, or the provision of, water structures or facilities located on a development as well as work to provide and connect a requested water main or communication pipe on, to or in the immediate vicinity of, the development and “site specific work” shall be construed accordingly. It does not refer to costs or work required as part of network reinforcement as defined above.
Undertaker	A water undertaker.
water main	Any pipe, not being a pipe for the time being vested in a person other us, which is used or to be used by the undertaker (or a licensed water supplier) for the purpose of making a general supply of water available to customers or potential customers of the undertaker or water supply licensee, as distinct from for the purpose of providing a supply to particular customers. This definition includes tunnels or conduits which serve as a pipe and any accessories for the pipe.
water sector guidance	The water sector guidance approved by Ofwat under the code for adoption agreements published in August 2018.

4. SURFACE TYPES

Surface Type	Description
Surfaced Ground (road/made ground)	These charges apply when work is being carried out in and / or under a road or footway with a sealed surface other than a private road.
Unmade ground (verge)	These charges apply to unfinished surfaces, which include tracks, fields, footpaths and / or private roads without a sealed surface or verges.
Excavation/Reinstatement by Customer	These charges apply where we do not undertake any excavation, backfilling or reinstatement, for example, where the trench has been pre-excavated by you to our standards. We only backfill and reinstate sites we have excavated.

- (1) Where measurements are referred to in these charging arrangements, they mean the following:
 - a. pipe diameter: all pipe diameters are specified in mm and unless indicated otherwise are outside diameters e.g. 25mm pipe has an outside diameter (o.d.) of 25mm (with an internal diameter (i.d.) of 20mm); and
 - b. pipe lengths are charged in linear metres rounded up to the next whole metre.
- (2) In the case of service connections, the two metre of service pipe tapped into the water main is included in the cost of connection. The applicable connection charge is determined by the surface type where the water main is tapped.
- (3) All charges in these charging arrangements are stated exclusive of any applicable VAT, unless otherwise specified.

5. PRE-DEVELOPMENT & POINT OF CONNECTION ENQUIRIES

5.1 INTRODUCTION

- (1) We want to engage with our developer customers at the earliest opportunity, to understand the how we can support growth in the Affinity Water region and to ensure we have the infrastructure and supply available at the right time for any given development.
- (2) We therefore actively encourage developers and self-lay providers to request a pre-development/point of connection study prior to any requisition for new mains, self-lay and / or diversions. The benefits of this study are as follows:
 - a. New Mains – provides you with early visibility of our needs to reinforce our existing network ahead of your development and allows us to advise you of any timing implication for your development.
 - b. Self-Lay – provides you with a point of connection to our network which enables you to carry out your design work which will deliver the levels of service for flow and pressure that you require for your development.
 - c. Diversions – enables you to be informed of any potential risks and hazards which you may need to address as part of your design for your development. The indicative budget estimate is not a cost advice for us to carry out the works.

5.2 PRE-DEVELOPMENT & POINT OF CONNECTION ENQUIRY FEES

- (1) For self-lay water mains, the water sector guidance expects self-lay providers to obtain a point of connection report where they are providing their own design.
- (2) To encourage the use of these services, both the pre-development enquiry and point of connection enquiry are free of charge (FOC). Upon receipt of a pre-development enquiry, we will review your enquiry, assess the point of connection into our existing network, prepare a budget estimate of the cost of the infrastructure of constructing the connection, water mains and communication pipes for your development, and produce a report which you can then refer to for your requisition, self-lay application or diversion application.

Table 5.2: Pre-development/Point of Connection Enquiry Fee			
Ref	Item	Unit	£ Excluding VAT
5.2.1	Pre-development/Point of Connection Enquiry	per enquiry	FOC

6. CHARGES SELF-LAY WATER MAINS

6.1 INTRODUCTION

- (1) An accredited self-lay provider (SLP) can carry out the contestable work for your development instead of Affinity Water. Many SLPs are able to offer a multi-utility option, which may you find more convenient to use to support your development.
- (2) This section of the charging arrangements sets out the charges to be paid in respect of the adoption of water mains pursuant to an adoption agreement.
- (3) Our design and construction standards determine the pipe material to be used for water mains and accessories to be laid by an SLP.
- (4) If you have proceeded on the basis of laying MDPE or HPPE pipes and during the works it is identified that the ground is contaminated so as to cause a risk of contamination to water in the water main then you will be required to install barrier pipe and appropriate accessories.

6.2 APPLICATION FEES

Ref	Item	Unit	£ Excluding VAT
6.2.1	Application Fee for self-lay mains (1-49 Properties)	per application	350
6.2.2	Application Fee for self-lay mains (50-100 Properties)	per application	400
6.2.3	Application Fee for self-lay mains (101+ Properties)	per application	450

- (1) The application fee(s) cover our costs associated with reviewing and acknowledging your application, checking to ensure we have all the relevant information, preparing a cost advice for the works, collating and preparing a report, preparation of the adoption agreement and issuing a response to you. If you have previously submitted a pre-development enquiry for this site, we will review any relevant documentation associated with that enquiry.
- (2) We request that the application fee(s) is paid at the point of application. We will start work on your application once we have received payment of the applicable application fee(s).

6.3 DESIGN & DESIGN REVIEW FEES

- (1) If you choose to have your design prepared by us, then the following charges will apply. These are consistent with the charges for Mains Design fees where we are requisitioned under Section 41 of the 1991 Act.

Table 6.3: Design Fees					
Ref	Item	Unit	£ Excluding VAT		
			Design Fee	Minor Design Change	Major Design Change
6.3.1	0-49 properties	per scheme / phase	750	FOC	375
6.3.2	50-100 properties	per scheme / phase	1,000	FOC	500
6.3.3	101+ properties	per scheme / phase	1,200	FOC	600
6.3.4	Review design prepared by developer or SLP. The first submitted design will be reviewed free of charge. Should we require any changes to be made at this point, we will also complete the first review of the amended design free of charge.	per scheme / phase	Free of Charge for the first design submission and first amended design if required.		

- (2) We request that a self-lay mains and services application includes information relating to your entire site. We will request for information relating to the phasing of this site and levy only one design fee within Table 6.3 above should you choose for Affinity Water to complete the design work on your behalf.
- (3) Where SLPs choose to submit a design for review by Affinity Water, the first design submission and first amended design will be vetted free of charge as per Table 6.3 above. We will always work with our customers to ensure the quality of design submission is of a high standard to negate the need for further submissions, however where a further amended design is requested, a charge equating to 50% of the appropriate major design change fee will be levied.
- (4) Our design and construction standards are published on our website at: <https://www.affinitywater.co.uk/developing/adoption-codes>

6.4 ADMINISTRATION FEES

- (1) These fees are shown in Table 6.4 below and they cover our costs associated with mobilising our construction team and project managing the works (connection to our water main), and integrating the as-laid information into our Geographical Information System and issuing the vesting certificate.

Ref	Item	Unit	£ Excluding VAT
6.4.1	Administration Fee 1-49 Properties	per application	500
6.4.2	Administration Fee 50-100 Properties	per application	550
6.4.3	Administration Fee 100+ Properties	per application	600
6.4.4	Additional Site Visit	per visit	102

- (2) We will agree with you at the outset of your project the number of site visits we will make before and during the course of you undertaking the self-lay works. Our charges for site visits are shown in Table 6.4 above. Site visits are intended solely to support you in undertaking your self-lay works and are not required for you to obtain our approval before you can progress any stage of the self-lay works.
- (3) We request that the administration fees are paid in advance of our works being completed.
- (4) If your project contains 300 plots or more, we request that your application is split into phases with the required level of detail regarding phasing submitted with that application. You will not be charged additional application or administration fees as a result.

6.5 CHARGES FOR CONNECTING ADOPTED WATER MAIN INTO WATER SUPPLY SYSTEM

Ref	Item	Unit	£ Excluding VAT		
			Surfaced Ground	Unmade Ground	Excavation / reinstatement by Customer
6.5.1	Under Pressure Connection / Branch Connection (50-190mm diameter parent main)	Per connection	1,764	1,482	1,300
6.5.2	Under Pressure Connection / Branch Connection (191-260mm diameter parent main)	Per connection	2,352	1,960	1,780
6.5.3	Under Pressure Connection / Branch Connection (261 - 320mm diameter parent main)	Per connection	2,862	2,385	2,018

- (1) These charges relate only to site specific work carried out and costs incurred by us in order to meet our duties under an adoption agreement to incorporate the self-laid water mains into our water network. They do not relate to work to modify or enhance existing network infrastructure in order to address pre-existing deficiencies in capacity or capability, unrelated to requirements associated with the adoption agreement.
- (2) These charges comprise the physical connection into our existing water network together with charges for any site-specific work we carry out to connect the self-laid water main to the point of connection to our existing water network.
- (3) Table 6.5a sets out our charges for providing a connection into our existing water network.
- (4) If you choose for us to carry out the construction of the off-site water mains, we will charge for this work in accordance with sections 8.5 to 8.10 of these charging arrangements.
- (5) Table 6.5b below sets out our charges for other services we provide under an adoption agreement in respect of self-laid water mains.

Table 6.5b Other services provided under adoption agreement for water mains			
Ref	Item	Unit	£ Excluding VAT
6.5.4	Take Water Sample / Additional site visit	per sample	102
6.5.5	Review Water Sample Analysis	per sample	19

- (6) Any defects we identify during our site audits need to be rectified prior to us carrying out the permanent connection to our existing network. If additional visits to your site (in excess of the two included in our administration fee) are required in order to verify that the defects have been rectified, we will charge on a per additional visit basis.

7. CHARGES - SELF-LAY SERVICE CONNECTIONS

7.1 INTRODUCTION

- (1) This section of the charging arrangements sets out the charges payable in respect of the adoption of communication pipes pursuant to an adoption agreement.

7.2 APPLICATION FEES

Table 7.2: Self-lay Service Connections Application Fees			
Ref	Item	Unit	£ Excluding VAT
7.2.1	Application Fee - Service Connections	per property / plot	20

- (5) Where a self-lay provider proposes to install a communication pipe to connect premises to our water mains for our adoption under an adoption agreement, the self-lay provider will need to pay us an application fee in accordance with Table 7.2.
- (6) We request that our application fees are paid at the point of application submission and are charged per property being connected to our network.
- (7) The reference to property in Table 7.2 above refers to any building or part of a building which is occupied or likely to be separately occupied (including a flat).
- (8) The application fee(s) cover our costs associated with reviewing your application, issuing the terms for service connections and preparing a cost advice for our charges associated with carrying out these connections (e.g. meters and infrastructure charges).

7.3 ADMINISTRATION FEES

- (1) When you are ready to install a communication pipe(s) you will need to pay us an administration fee calculated in accordance with Table 7.3. Our administration fees are charged per property that is being connected.

Table 7.3: Self-lay Administration Fees			
Ref	Item	Unit	£ Excluding VAT
7.3.1	Administration Fee (all properties connected)	per connection	40

- (2) The reference to properties in Table 7.3 refers to any building or part of a building which is occupied or likely to be separately occupied (including a flat).
- (3) Administration fees relate to the work we do including integrating the as-laid information into our Geographical Information System and creating customer accounts.
- (4) We request that our administration fees are paid prior to any works being carried out.

7.4 SUPPLY OF METERS:

Table 7.4 below sets out our charges for the provision of water meters for installation by self-lay providers. The Self-Lay adoption agreement will specify when these charges will become due.

Table 7.4: Supply of Meters				
Ref	Item	Meter Size	Unit	£ Excluding VAT
7.4.1	15MM MANIFOLD AMR METER / AQP15MSB315VMEE31	15MM	per item	45
7.4.2	15MM INLINE AMR METER COMPLETE WITH UNIONS AND WASHERS	15MM	per item	49
7.4.3	20MM INLINE AMR METER COMPLETE WITH UNIONS AND WASHERS	20MM	per item	67
7.4.4	25MM INLINE AMR METER COMPLETE WITH UNIONS AND WASHERS	25MM	per item	133
7.4.5	40MM INLINE AMR METER COMPLETE WITH UNIONS AND WASHERS	40MM	per item	187
7.4.6	WOLTEX 50MM METER FITTED WITH EVERBLU WE050HI200-C1PP-AF	50MM	per item	224
7.4.7	WOLTEX DN80 FITTED WITH EVERBLU WE080II200 - C1PP-AF	80MM	per item	275
7.4.8	WOLTEX DN100 FITTED WITH EVERBLU WE100KK250-C1PP-AF	100MM	per item	323
7.4.9	METER WOLTEX 150mm WE150MK300-C1PP-AF	150MM	per item	468
7.4.10	WOLTEX DN200 PN16 Q3 With Pressure Plug	200MM	per item	559
7.4.11	WOLTEX DN250 PN16 Q3 With Pressure Plug	250MM	per item	755

8. REQUISITION CHARGES (NEW MAINS)

8.1 INTRODUCTION

- (1) This section of these charging arrangements charges sets out our requisition charges.
- (2) Requisition charges are concerned with the cost to us of providing site specific infrastructure necessary for the provision of a water main. Such charges do not include any amount for network reinforcement costs.

8.2 APPLICATION FEES

Ref	Item	Unit	£ Excluding VAT
8.2.1	Application Fee for Mains (0-49 Properties)	per application	450
8.2.2	Application Fee for Mains (50-100 Properties)	per application	500
8.2.3	Application Fee for Mains (100+ Properties)	per application	550

- (1) Where you request us to provide water mains to service your development, the charges in Table 8.2 will apply.
- (2) The application fee covers our costs associated with reviewing and acknowledging your application, checking to ensure we have all the relevant information, preparing a cost advice and/or fixed charge for the works, and issuing a response to you. Please note that this does not cover the cost of design which is charged in addition to the application fee (see section 8.3 below). If you have previously submitted a pre-development enquiry for your development, we will review any relevant documentation associated with that enquiry.
- (3) The application fee(s) is payable at the time you submit your application for new water mains and service connections. We will start work on your application when we have received payment of the applicable application fee(s).

8.3 DESIGN FEES

Table 8.3: Design Fees					
Ref	Item	Unit	£ Excluding VAT		
			Design Fee	Minor Design Change	Major Design Change
8.3.1	0-49 properties	per scheme / phase	750	FOC	375
8.3.2	50-100 properties	per scheme / phase	1,000	FOC	500
8.3.3	101+ properties	per scheme / phase	1,200	FOC	600
8.3.4	Review design prepared by developer or self-lay provider. The first submitted design will be reviewed free of charge. Should we require any changes to be made at this point, we will also complete the first review of the amended design free of charge.	per scheme / phase	Free of Charge for the first design submission and first amended design if required		

- (1) In order for us to provide you with a cost advice and / or fixed charge for your development we will need to prepare a design. Our charges for this service are based on the number of properties which will be served and are set out in Table 8.3. Where you indicate to us that your development will be built in multiple phases the applicable design fee is based on the number of properties which will be connected during each phase.
- (2) The design fee(s) are payable at the time you submit your application. We will start work on your design when we have received payment of the applicable design fee(s).
- (3) We request that an initial mains application includes information relating to your entire site, including all phasing information.
- (4) We understand that your requirements may change after we issue a design and cost advice to you. If we have prepared the design(s) for your development and you inform us of a change in your requirements for the development, we may need to issue you with a revised design and there may be a charge for this, depending on whether it is a minor change or major change. This is defined below.
- (5) A minor design change is:
 - a. a change to the site boundary; or
 - b. a change to the size of the water main; or

c. adding, removing or changing the location of the communication pipes.

We understand the complexities and nature of the work involved with managing development sites, therefore as outlined in Table 8.3 above, these changes are completed free of charge.

(6) A major design change is:

- a. a change of route or layout of the water mains on site; or
- b. a change to the point of connection of new water mains to the existing network; or
- c. a change to the overall water demand of the site; or
- d. changing the phasing plan

For the above changes, we will request a re-design fee which equates to 50% of the initial design fee, as outlined in Table 8.3 above. If your development has been split into phases, this charge will be levied on each of the phases which are impacted by the change in requirements.

(7) Where you choose to submit a design for review by Affinity Water, the first design submission and first amended design will be vetted free of charge as per Table 8.3 above. We will always work with our customers to ensure the quality of design submission is of a high standard to negate the need for further submissions, however where a further amended design is requested, or where a resubmission still does not comply with our design and construction standards, a charge equating to 50% of the appropriate major design change fee will be levied for each subsequent revision.

8.4 ADMINISTRATION FEES

(1) Our administration fees reflect the costs we incur for planning, organising, project managing, inspecting and commissioning the construction of the water main to serve your development and are identified in Table 8.4 below.

Table 8.4: Mains Administration Fees			
Ref	Item	Unit	£ Excluding VAT
8.4.1	Mains Administration Fee 0-49 Properties	per application	1,000
8.4.2	Mains Administration Fee 50-100 Properties	per application	1,100
8.4.3	Mains Administration Fee 100+ Properties	per application	1,200

(2) We request the administration fees to be paid before we provide the services stated.

(3) If your project contains 300 plots or more, we request that your application is split into phases with the required level of detail regarding phasing submitted with that application. You will not be charged additional application or administration fees as a result.

8.5 CHARGES FOR LAYING WATER MAINS

Table 8.5: laying of water mains – Includes accessories specified in our design and construction standards						
Ref	Item	Unit	£ Excluding VAT			
			Surfaced Ground	Unmade Ground	Excavation / Reinstatement by Customer	Barrier Pipe Uplift (%)
8.5.1	Lay Pipe (50-100mm)	Per linear metre	270	100	59	15%
8.5.2	Lay Pipe (101-130mm)		280	110	62	21%
8.5.3	Lay Pipe (131-190mm)		350	130	83	26%
8.5.4	Lay Pipe (191-260mm)		400	180	130	31%
8.5.5	Lay Pipe (261-320mm)		500	240	172	36%

Note: For contaminated ground / barrier pipe - please select the appropriate surface rate and add the uplift % to provide the correct charge.

- (1) Our charges for laying mains depend on a number of factors including:
 - a. the diameter and length of the new water main you require; and
 - b. the number and arrangement of fittings required to meet our design and construction standards; and
 - c. the type of ground in which the water main is laid or if you have chosen to carry out the excavation and reinstatement yourself; and
 - d. whether the soil may be (or is) contaminated.

- (2) You can estimate the sizing of the pipework for your new water main. The list below is a general guide for the typical sizing of new water mains required for household properties. Please note the list is for indicative purposes only once the detailed design is carried out, the size required may be different:
 - Pipe diameter (50-100mm) Up to 60 houses or 100 flats
 - Pipe diameter (101-130mm) Up to 130 houses or 230 flats
 - Pipe diameter (131-190mm) Up to 400 houses or 700 flats
 - Pipe diameter (191-260mm) Up to 900 houses or 1,500 flats
 - Pipe diameter (261-320mm) Up to 2,600 houses or 4,500 flats

Further guidance regarding sizing methodology can be found on our website (www.affinitywater.co.uk).

- (3) Our fixed charges for your new water mains are limited to the cost of connecting to the nearest reasonably practicable point on our network, where the existing water main is at least the same diameter as your new water main required to provide the capacity for your development.
- (4) Our design and construction standards determine the pipe material to be used for water mains and accessories and can be found here - <https://www.affinitywater.co.uk/docs/developer/Design-construction-specification.pdf>
- (5) Table 8.5 sets out our charges for laying water mains to serve your development. These charges include the accessories specified in our design in accordance with our design and construction standards.

8.6 CHARGES FOR INSTALLING ADDITIONAL ACCESSORIES

- (1) Table 8.6 sets out our charges for installing additional accessories such as fire hydrants at the request of the applicant or fire and rescue authority that are not specified in our design.

Table 8.6: Installation of Accessories – Hydrants & Washouts (MDPE / HPPE & Barrier Pipe)					
Ref	Item	Unit	£ Excluding VAT		
			Surfaced Ground	Unmade Ground	Excavation / Reinstatement by Customer
8.6.1	Fire Hydrant or Wash Out (<u>In-line</u> , 50-190mm pipe)	Per accessory	1,074	936	880
8.6.2	Fire Hydrant or Wash Out (<u>In-line</u> , 191-320mm pipe)		1,477	1,468	1,388
8.6.3	Fire Hydrant or Wash Out (<u>End type</u> , 50-190mm pipe)		930	784	730
8.6.4	Fire Hydrant or Wash Out (<u>End type</u> , 191-320mm pipe)		1,144	1,107	1,055

8.7 CHARGES FOR CONNECTING WATER MAINS INTO SUPPLY SYSTEM

- (1) Table 8.7 sets out our charges for connecting the water mains constructed to serve your development to our existing water supply system. This will include installation of sluice valves in accordance with our design.

Ref	Item	Unit	£ Excluding VAT		
			Surfaced Ground	Unmade Ground	Excavation / Reinstatement by Customer
8.7.1	Under Pressure Connection / Branch Connection (50-190mm diameter parent main)	Per connection	1764	1,482	1,300
8.7.2	Under Pressure Connection / Branch Connection (191-260mm diameter parent main)	Per connection	2,352	1,960	1,780
8.7.3	Under Pressure Connection / Branch Connection (261 - 320mm diameter parent main)	Per connection	2,862	2,385	2,018

8.8 NETWORK REINFORCEMENT

- (1) We will notify you of any network reinforcement that we need to undertake in consequence of your development and explain the time/cost implications for your development.
- (2) Where the water main you are connecting to is equal to or greater than the new main, we will not charge you our costs of undertaking any network reinforcement required to serve your development.

8.9 NETWORK ENHANCEMENT

- (1) Where we provide a water main pursuant to a requisition and, in so doing, decide to increase the capacity of pipes or other infrastructure beyond that which is needed to meet our duty under section 41(1) of the 1991 Act, then the costs of this work shall, if this increases the overall costs of the work, be apportioned so that you only pay costs which are in proportion to the particular capacity required by your requisition.

8.10 EXCEPTIONAL CIRCUMSTANCES

- (1) Fixed charges will not apply in respect of requisition charges in the following circumstances:
- the technical complexity of the work is high, or the type of work required is bespoke or carried out infrequently; or
 - third parties can legitimately recover their costs from us and there is not a reasonable level of certainty of those costs in advance of connection work being undertaken; or

- c. third parties have rights to protect their assets or interests in a way that affects the construction method or timing (including protected undertakings). The third parties' requirements are unknown in advance; or
 - d. the work is to be carried out on or close to land with particular environmental, historical or archaeological characteristics. These characteristics mean that specific measures are required during construction or reinstatement. The details of these measures may not be fully defined in advance of construction; or
 - e. the work is to be carried out in or under sealed surfaces other than sealed surfaces formed of materials specified in the Specification for the Reinstatement of Openings in Carriageways (third edition) (for example printed concrete, marble and specialist stone).
- (2) In these circumstances, charges will comprise a combination of:
- a. upfront fixed charges for the elements of the work where there is sufficient certainty and it is reasonable to do so; and
 - b. charges calculated on the basis of the actual cost we incur in respect of other elements of work.
- (3) We will provide you with a document which clearly states fixed charges and charges calculated by actual costs incurred.
- (4) We anticipate that there will be occasions where providing an indicative estimate is not possible or where the estimate will not meet the degree of confidence you require. In such cases, we will work with you to decide how best to proceed.

9. CONNECTION CHARGES

9.1 INTRODUCTION

- (1) This section of the charging arrangements sets out our connection charges.
- (2) Connection charges imposed by us relate only to site specific work carried out and the costs incurred by us pursuant to sections 45(1) or 46(1) of the 1991 Act.

9.2 APPLICATION FEES

- (1) Where you need us to make a connection(s) to our water mains, you must pay us the applicable application fee(s) set out in Table 9.2. Our application fees are charged per property that is being connected.

Ref	Item	Unit	£ Excluding VAT
9.2.1	Application Fee – Connection off Existing Main (first property connected)	per application	120
9.2.2	Application Fee – Connection off Existing Main (each subsequent property connected)	per property/plot	30
9.2.3	Application Fee – Connection off New Main	per property/plot	40

- (2) The reference to property in Table 9.2 above refers to any building or part of a building which is occupied or likely to be separately occupied (including a flat).
- (3) The application fee(s) cover our costs associated with reviewing and acknowledging your application, checking to ensure we have all the relevant information, and preparing and providing you with a cost advice for your service connection(s).
- (4) In order for us to carry out your design we may visit your site to carry out a survey. In the event that we do so, there will be no additional charge for this visit.
- (5) The application fee(s) is payable at the time you submit your application for service connections and, where applicable, new water mains. We will start work on your application when we have received payment of the applicable application fee(s).
- (6) Please refer to our website for a step-by-step guide to what information we require from you and when - <https://www.affinitywater.co.uk/developing/connection>

9.3 ADMINISTRATION FEES

- (1) Administration fees relate to the work we do to plan, organise, manage, and commission your service connection(s) and also the work we need to do to verify and record the relevant details of each supply. These charges can be found in Table 9.3 below.
- (2) These charges will appear on our cost advice to you and will become due should you decide to progress with the works relating to the installation of the service connections.

Table 9.3: New Connections Administration Fees			
Ref	Item	Unit	£ Excluding VAT
9.3.1	Administration Fee (each property connected)	per property/plot	80

- (3) The reference to property in Table 9.3 refers to any building or part of a building which is occupied or likely to be separately occupied (including a flat).

9.4 CONNECTION CHARGES

Table 9.4a: Installation of connections (MDPE/HPPE) (meters are included except where stated otherwise)						
Ref	Pipe Diameter	Unit	£ Excluding VAT			
			Surfaced Ground	Unmade Ground	Excavation / Reinstatement by Customer	Barrier Pipe Uplift (%)
Tap in & connection (MDPE/HPPE) only- (including up to 2 metre of pipe) – surface type is determined at the point of connection to the main						
9.4.1	25-32mm	Per connection Single:	1,250	584	365	15%
9.4.2		2-port connections:	1,400	914	502	15%
9.4.3	50mm-63mm	Per connection Single (without meter):	1,650	938	658	15%
9.4.4		3-port connections:	2,000	1,316	990	15%
9.4.5		4-port connections:	2,100	1,366	1,137	15%
9.4.6		5-port connections:	2,300	1,614	1,301	15%
9.4.7		6-port connections:	2,400	1,664	1,351	15%
9.4.8	80-90mm	Per connection Single (without meter):	4,500	4,204	3,731	15%

9.4.9	100-130mm	Per connection Single (without meter):	4,800	4,327	3,801	20%
9.4.10	150-180mm	Per connection Single (without meter):	5,000	4,524	3,998	25%
9.4.11	190-260mm	Per connection Single (without meter):	5,500	5,000	4,500	30%

Note: For contaminated ground / barrier pipe - please select the appropriate surface rate and add the uplift to provide the correct charge.

- (1) Our charges for new connections depend on a number of factors including:
 - a. the type of ground or if you have chosen to carry out the excavation and reinstatement yourselves; and
 - b. the pipe diameter and length of service pipe as applicable to your required demand; and
 - c. whether the soil may be (or is) contaminated.
- (2) Our fixed charges for your service connection(s) are limited to the cost of connecting to the nearest reasonably practicable point on our network where the existing water main is at least the same diameter as your service connection, in order to provide the capacity for your development.
- (3) We will make no additional connection charge in the event that we change the point of connection for capacity reasons. However, if the nearest available main is smaller than the connection required to support your development, we will provide you with the reinforcement costs required.
- (4) Our design and construction standards determine the pipe material to be used for service pipes and accessories and can be found here - <https://www.affinitywater.co.uk/docs/developer/Design-construction-specification.pdf>
- (5) The charges set out in Table 9.4a include (unless otherwise specified) the provision and installation of externally located water meters where required for billing purposes.
- (6) Tables 9.4b, 9.4c and 9.4d below set out charges for additional pipe laying, accessories as part of the connection(s) and meters.

Table 9.4b: Installation of connections: Additional Pipe Laying (MDPE/HPPE)						
Ref	Item	Unit	£ Excluding VAT			
			Surfaced Ground	Unmade Ground	Excavation / Reinstatement by Customer	Barrier Pipe Uplift (%)
Service Pipe Laying						
9.4.12	Lay Pipe (25-32mm)	Per linear metre	240	100	34	15%
9.4.13	Lay Pipe (50-63mm)		250	105	46	15%
9.4.14	Lay Pipe (80-100mm)		260	110	62	15%
9.4.15	Lay Pipe (101-130mm)		270	115	69	20%
9.4.16	Lay Pipe (131-190mm)		330	140	92	25%
9.4.17	Lay Pipe (191-260mm)		400	210	144	30%
9.4.18	Lay Pipe (261-320mm)		500	240	185	35%

Note: For contaminated ground / barrier pipe - please select the appropriate surface rate and add the uplift to provide the correct charge.

Table 9.4c: Installation of internal meters (e.g. flats fed from large supplies)			
Ref	Item	Unit	£ Excluding VAT
9.4.19	Install Internal 15mm Screw-in Meter (includes meter)	Per property / item	103

Table 9.4d: Installation of Accessories – In-line meters in conjunction with other works.					
Ref	Item	Unit	£ Excluding VAT		
			Surfaced Ground	Unmade Ground	Excavation / Reinstatement by Customer
9.4.20	Install in-line meter - 40mm in conjunction with item 7.4.3 where required.	Each	303		
9.4.21	Install in-line meter - 50mm in	Each	348		

	<i>conjunction with item 7.4.3 where required.</i>				
9.4.22	Install in-line meters - 80mm	Per accessory	1,845	1,442	1,353
9.4.23	Install in-line meters - 100mm		2,007	1,551	1,469
9.4.24	Install in-line meters - 150mm		2,326	1,770	1,678
9.4.25	Install in-line meters - 200mm		2,500	2,100	2,000
9.4.26	Install in-line meters - 250mm		3,142	2,500	2,300

10. DEVELOPER DIVERSION CHARGES

10.1 INTRODUCTION

- (1) This section of the charging arrangements sets out the method(s) for calculating charges pursuant to Section 185 of the 1991 Act in respect of the diversion or removal of pipes up to 315mm outside diameter located in, under or over land in which you have an interest or in any adjacent land in which you have an interest.
- (2) Diversion charges are calculated by reference to the principle that we are entitled to recover the costs reasonably incurred as a result of complying with the duty imposed on us by Section 185(1) of the 1991 Act.
- (3) This section does not apply to diversions for Highway authorities under the

NEW ROADS AND STREET WORKS ACT 1991 - DIVERSIONARY WORKS SA10/05

applicable to England, Scotland and Wales only. Please contact Developer Services for advice on your diversion requirements which are subject to these regulations.

10.2 APPLICATION FEES

Table 10.2: Diversion Application Fees			
Ref	Item	Unit	£ Excluding VAT
10.2.1	Application Fee for diversion	per application	300

- (2) When submitting an application (under Section 185 of the 1991 Act) for us to divert existing water mains as part of your development, the above application fee will apply.
- (3) The application fee covers our costs associated with reviewing and acknowledging your application, checking to ensure we have all the relevant information, preparing a cost advice for the works, and issuing a response to you. Please note that this does not cover the cost of design which is charged in addition to the application fee (see section 10.3 below). If you have previously submitted a pre-development enquiry for this site, we will review any relevant documentation associated with that enquiry.
- (4) The application fee(s) will be levied at the point of application. Once we have confirmed payment, we will progress with your diversion application.

10.3 DESIGN FEE

- (1) In order for us to provide you with fixed charges for your diversion, we will need to prepare a design. Our fee for the design of the diversion of a water main of up to 180mm diameter is shown in Table 10.3 below.

Table 10.3: Diversion Design Fees			
Ref	Item	Unit	£ Excluding VAT
10.3.1	Diversion of a main up to 315mm diameter	per design	1,000
10.3.2	Diversion re-design fee	per design	500

- (2) We understand that your requirements may change after we issue a design and cost advice to you. If we have prepared the design(s) for your development and you inform us of a change in your requirements for the development, due to the nature of diversionary works, we will require a re-design fee of 50% of the original design charge.
- (3) For diversions over 315mm diameter, our fees will be our reasonably incurred costs of undertaking this work.

10.4 ADMINISTRATION FEES

- (1) Administration fees relate to services we provide in connection with the diversion of our water mains. Our administration fees reflect the costs we incur for planning, organising, project managing, inspecting and commissioning the diversion of our water main. These charges can be found in Table 10.4 below.
- (2) These charges will appear on our cost advice to you and will become due should you decide to progress with the diversionary works.

Table 10.4: Diversion Administration Fees			
Ref	Item	Unit	£ Excluding VAT
10.4.1	Diversion Administration Fee	per application	800

10.5 DIVERSION CHARGES / CUTTING AND CAPPING EXISTING WATER MAINS

Table 10.5: Cutting and capping existing water main					
Ref	Item	Unit	£ Excluding VAT		
			Surfaced Ground	Unmade Ground	Excavation / Reinstatement by Customer
10.5.1	Cut and Cap Existing Main (50-100mm diameter pipe)	Per item	1,200	900	720
10.5.2	Cut and Cap Existing Main (101mm -130mm diameter pipe)		1,450	1,050	801
10.5.3	Cut and Cap Existing Main (131-190mm diameter pipe)		1,600	1,150	887
10.5.4	Cut and Cap Existing Main (191-260mm diameter pipe)		1,800	1,200	900
10.5.5	Cut and Cap Existing Main (261-315mm diameter pipe)		1,900	1,250	950

- (1) For diversion works other than for a Highway authority our diversion charges will comprise of upfront fixed charges for the elements of work identified as a result of the design.
 - a. For mains over 315mm, this will be costed by exception upfront and reconciled using actual costs post completion. This methodology can be requested for diversions below 315mm if specifically required.
- (2) We anticipate that there will be occasions where providing an indicative estimate is not possible or where the estimate will not meet the degree of confidence you desire. In such cases, we will work with you to decide how best to proceed.
- (3) For diversion works for a Highway Authority please contact Developer Services to obtain a bespoke cost estimate in accordance with the New Roads and Street Works Act 1991 Diversionary Works.

11. TRAFFIC MANAGEMENT

- (1) Where additional costs are payable as a result of traffic management and highway authority charges, we have provided upfront fixed charges which will be highlighted as a separate item in your cost advice. These charges can be found in Table 11.1 below.

Table 11.1: Traffic Management			
Ref	Item	Unit	£ Excluding VAT
11.1.1	2 Way Traffic Lights (Automated)	Each (In Working Hours)	840
11.1.2	3 Way Traffic Lights (Automated)	Each (In Working Hours)	926
11.1.3	4 Way Traffic Lights (Automated)	Each (In Working Hours)	1,006
11.1.4	1 Person – Manually Operated Stop/Go	Per Day	1,375
11.1.5	2 Person – Manually Operated Stop/Go	Per Day	1,687
11.1.6	Road Closure (Small – up to 10 Signs)	Each	2,271
11.1.7	Road Closure (Medium – up to 20 Signs)	Each	2,299
11.1.8	Road Closure (Large – up to 30 Signs)	Each	2,558

- (2) Upfront fixed costs for road closures have been provided to ensure cost predictability and stability for our developer customers. This has been implemented in response to positive feedback in our 21/22 new connections charging consultation. Should you wish to be charged for a road closure on an actual cost basis, this can be requested at cost advice stage.

12. OUT OF HOURS WORKING

- (1) Our preference is always to carry out works within working hours as this avoids adverse impact to the rest of our operations. However, it may be necessary to carry out some or all of the works involved in constructing the water main for your development outside of working hours. In most cases this is determined by the local authority and is due to the impact the construction works will have on others.
- (2) Where additional costs will be incurred, we will reconcile the upfront fixed costs with our actual costs in order to appropriately recover these charges.

13. MISCELLANEOUS CHARGES

- (1) This section of the charging arrangements sets out the charges for miscellaneous services provided. Relevant charges are listed in Table 13.1 below.

Table 13.1: Miscellaneous Charges			
Ref	Item	Unit	£ Excluding VAT
13.1.1	Approved Plumber or Groundworker Discount (external pipework only)	Per plot connection	(15)
13.1.2	Water regulations inspection (where Affinity Water inspects service connections laid by others).	Per inspection	102
13.1.3	Site Visit: To provide additional guidance and advice.	One technician for one hour	102
13.1.4	Supervision of traffic management where required by local authority (or other such organisation).	Per person per hour	102
13.1.5	Aborted work	per application	50% of appropriate Admin fee

- (2) Where you have accepted our cost advice and / or fixed charges and paid us the relevant charges that are due to that point and subsequently notify us that you no longer need us to carry out the installation works, we may charge you a fee for our services carried out to that point. This may include costs associated with cancelling the scheduling of the works and any costs we have incurred through our supply chain.
- (3) With respect to situations which may arise which cause our works or activities to be aborted, and this is assessed to be as a result of the customer, such as your site not being ready when we attend on an agreed day to carry out our works, we are able to levy the following charges:
- abortive administration fee; plus
 - all additional costs we have to pay to the Highway authority to re-book any permits, suspensions or closures; plus
 - any additional costs associated with abortive charges, lost time, remobilisation, planning, enabling, plant and supervision.

This includes situations where we consider the site, for whatever reason, to be unsafe.

- (4) We are committed to ensuring high quality work is completed to ensure safe drinking water for all our customers. With this in mind, we are introducing a £15 discount per plot when a Water Industry Approved Plumbers Scheme (WIAPS) certificate is submitted for review to support the use of an accredited contractor for the external pipework. Note the following:
- Please note, this discount is only applicable to the customer side pipework that is external to the property/premises as shown in the diagram below:

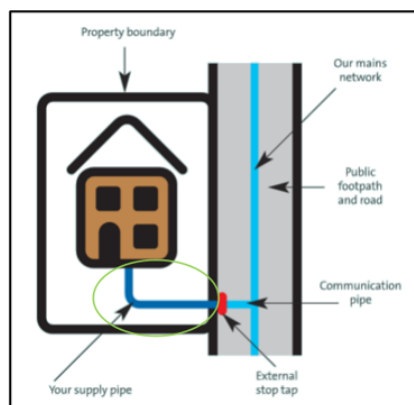

Figure 13.4a – Approved contractor pipework eligibility

- b. To find an approved plumber and/or groundworker, you can search here - https://www.watersafe.org.uk/approved_plumbers/
- c. The approved contractor must be certified for 'underground pipework' activities.
- d. We request that certificates are provided to cover every plot whereby the discount has been applied.
- e. Affinity Water reserve the right to carry out Water Regulations inspections to ensure the certified work meets the requirements under the Water Supply (Water Fittings) Regulations 1991.
- f. This discount applies where call off connection requests occur within this relevant charging year and will not be retrospectively levied.

14. PAYMENT TERMS

14.1 INTRODUCTION

- (1) Your cost advice document will be issued based on the relevant charging year at that time.
- (2) We will apply the income offset credit(s) against the infrastructure charge(s) at the time we issue your cost advice and design documents.
- (3) Prior to any works being carried out, we request all charges are paid.
- (4) The methods of payment are as follows:
 - a. Credit card or debit card payments online through our customer portal
 - b. BACS
 - c. Credit card or debit card payments over the phone
 - d. Cheques

Further detail on methods of payment will be provided in your cost advice.

15. TRANSITIONAL ARRANGEMENTS

15.1 COST ADVICE DOCUMENTS FOR SITE SPECIFIC WORK

- (1) Cost advice for site specific work which have been accepted on or before 31 March 2021 in respect of works to be carried out on or after 1 April 2021 will continue to apply unless we agree with the developer to vary the cost advice to reflect these charging arrangements.
- (2) Where an adoption agreement is in place on or before 31 March 2021 the charges and payments set out in that agreement will continue to apply unless we agree with the self-lay provider to vary those charges and payments.
- (3) For applications received between 1 February 2021 and 31 March 2021 in respect of site specific work to be carried out on or after 1 April 2021, developers and self-lay providers will be able to choose whether to be charged in accordance with these charging arrangements or the basis of the previous year's charging arrangements, applicable up to and including 31 March 2021.
- (4) Developers or self-lay providers that have received a cost advice or draft adoption agreement on or before 31 January 2021 but have not formally accepted can re-apply on or after 1 February 2021 for a cost advice in accordance with these charging arrangements.
- (5) For all cost advice issued between 31 January 2021 and 31 of March 2021, we will honour the charges within the cost advice for 180 days (from date cost advice issued).
- (6) The works must be accepted and paid for prior to commencement and no later than the 31 July 2021.

16. INFRASTRUCTURE CHARGES & ASSOCIATED CREDITS

Please note: This section does not strictly form part of these charging arrangements, however for ease, we have included them here. Please refer to the Affinity Water Charges Scheme 2021/22 for the definitions of terms used in this section.

16.1 INTRODUCTION

- (1) The purpose of an infrastructure charge is to enable a charge to be levied to reflect broadly the expected additional load placed on our network by the connection of premises not previously connected to it. Infrastructure charges do not relate to the costs of reinforcing, upgrading or otherwise modifying existing network infrastructure in order to address pre-existing deficiencies in capacity or in capability.
- (2) The provisions of this section 15 do not apply to premises connected on or after 1 April 2018 to a water main:
 - a. provided by us under section 41 of the 1991 Act where the charges for that water main were calculated on the basis of the provisions of the 1991 Act before they were amended by the Water Act 2014; or
 - b. that was or will be adopted by us in accordance with an agreement made pursuant to section 51A of the 1991 Act to which charging rules made by Ofwat under section 51CD of the 1991 Act do not apply.

16.2 WHEN DOES AN INFRASTRUCTURE CHARGE ARISE?

- (1) An infrastructure charge is levied for the connection (whether directly or indirectly) of any premises (not previously connected to a supply of water provided by us or another water undertaker) using water for domestic purposes, to our existing network of mains. This will include cases where a site is being developed or redeveloped by means of the conversion or extension of an existing building or buildings, resulting in a significant increase in demand. This charge is payable in addition to those made for providing a connection pipe and, where necessary, a water main.

16.3 LIABILITY FOR INFRASTRUCTURE CHARGES

- (1) Infrastructure charges are payable by the person making or requesting the connection to any premises on whose behalf the connection or request for connection is made. Charges as set out in the schedule of charges will apply.
- (2) The occupier of each house subject to a common billing agreement will be liable to pay us one standard water infrastructure charge in respect of that house where:
 - a. a person who has received a demand, or undertaken to pay infrastructure charges in respect of two or more houses subject to a common billing agreement fails to pay them, or any part of them, within 14 days of the date of connection; or
 - b. a common billing agreement is terminated otherwise than in accordance with its terms by the person who has undertaken to pay charges under it.
- (3) In these circumstances, we will give credit for any amount already paid by way of infrastructure charges in respect of that house for the connection concerned.

16.4 CALCULATION OF THE INFRASTRUCTURE CHARGE

- (1) The standard water infrastructure charge will apply except in the case of:
- houses subject to a common billing agreement where the infrastructure charge for each house will be the standard water infrastructure charge multiplied by the relevant multiplier for that house; and
 - premises other than houses to which water is provided by a supply pipe above the standard size (25mm) where the infrastructure charge for the premises will be the standard water infrastructure charge multiplied by the relevant multiplier for those premises.

16.5 DETERMINING THE RELEVANT MULTIPLIER

- (1) Infrastructure charges are based on the load that the development is placing on the system. To assess these charges, the total number of water units is expressed as a number of loading units as detailed in Table 16.5 below.

Table 16.5: Relevant Multiplier Loading Units	
Water Fitting ¹	Loading Units
WC flushing cistern	2.0
Wash basin in a House	1.5
Wash basin elsewhere	3.0
Bath (tap nominal size 3/4in/ 20mm) ²	10.0
Bath (tap nominal size larger than 3/4in/ 20mm) ²	22.0
Shower	3.0
Sink (tap nominal size 1/2in/ 15mm)	3.0
Sink (tap nominal size larger than 1/2in/ 15mm)	5.0
Spray tap	0.5
Bidet	1.5
Domestic appliance (subject to a minimum of 6 loading units per House) ^{3 and 4}	3.0
Communal or commercial appliance ³	10.0
Any other water fitting or outlet (including a tap but excluding a urinal or water softener)	3.0
Notes to table:	
1. Reference to any fitting includes reference to any plumbing, outlet, dedicated space or planning or other provision for that fitting.	
2. Including a whirlpool or Jacuzzi.	
3. Domestic appliance means an appliance (including a dishwasher, a washing machine and waste disposal unit) in a house and communal or commercial appliance means an appliance (including a dishwasher, a washing machine and waste disposal unit) elsewhere than in a house (including communal facilities).	
4. In calculating the relevant multiplier a minimum of 6 loading units in respect of each house will be included for domestic appliances (whether or not the house has any such appliances) except, in the case of any house , where neither a washing machine nor a dishwasher can be provided (and there is no plumbing, outlet, dedicated space or planning or other provision for either appliance) in the house .	

- (2) To calculate the relevant multiplier for houses subject to a common billing agreement:
- Determine the aggregate loading units; and

- b. Divide this number by 24; and
 - c. Divide the result by the number of houses subject to the common billing agreement.
- (3) To calculate the relevant multiplier for premises other than houses to which water is provided by a supply pipe above the standard size (25mm):
- a. Calculate the aggregate loading units; and
 - b. Divide this number by 24.

16.6 CREDITS

- (1) Where a site is redeveloped or a building is converted, and still has a metered supply of up to 25mm, a credit of one standard water infrastructure charge will be given for each premises on the site previously connected to our water supply in the five years beforehand.
- (2) Where the site to be developed has a metered supply greater than 25mm, credits will be allowed against the number of fittings previously used. In the absence of fittings data, a credit of one standard water infrastructure charge will be awarded for each premises on the site previously connected to our water supply in the five years beforehand.

16.7 INCOME OFFSET

- (1) An income offset payment under these charging arrangements for all new connections where an infrastructure charge is applicable. The income offset is against the infrastructure charge not the mains requisition cost following the policy change in Ofwat's Charging Rules.
- (2) We will apply an income offset for each new connection where an infrastructure charge is applicable.
- (3) The income offset is currently set at £387.26 based on historic capital spend and historic connections volumes, taking into account CPIH increases.

Table 16.7: Income Off-Set Calculation		
Description	Percentage Uplifts	£ Excluding VAT
Total Income Offset / Asset payments for period 19/20		4,237,323
Total number of valid domestic connections to New Mains for the period 19/20		11,002
Calculated income Offset Value		385.14
CPIH Increase November 2020	0.55%	2.12
Calculated Income Asset Value for 1 April 2021		387.26

16.8 INCOME OFFSET PAYMENT

- (1) An income offset payment will be levied against the infrastructure charge at the upfront cost-advice stage.
- (2) An income offset payment will not be applicable to service connections to new Mains schemes that have already received an income offset to the requisitioned mains cost.
- (3) An income offset payment will not be due to service connections on self-lay schemes that have already received an asset payment for the adopted mains.

16.9 WATER EFFICIENT DEVELOPMENT CREDIT

- (1) Building Regulations include the requirement for all new dwellings to achieve a water efficiency standard of 125 litres of water per person per day.
- (2) Building Regulations part G include an optional requirement of 110 litres of water per person per day for new residential development, which should be implemented through local policy where there is clear evidence needed.
- (3) We operate in areas of serious water stress and support the inclusion of a water efficiency standard of 110 litres per person per day being included in planning policies.
- (4) To help promote the achievement of this objective, we will apply a discount to the infrastructure charge for new homes where there is evidence of water efficiency design to a standard of 110 litres (or less) per person per day. The discount will be £80 per infrastructure charge.

16.10 INFRASTRUCTURE CHARGE

Table 16.10: Infrastructure Charge	£ Excluding VAT		
	2019/20	2020/21	2021/22
Charging period			
Standard water infrastructure charge	375	375	249

17. NEW APPOINTEES

- (1) This section does not form part of these charging arrangements but the information provided is intended to set out our approach to charges in respect of site specific water mains required to connect into our water supply system to facilitate the provision of a bulk supply of water by us to the New Appointee. Such charges and payments would be reflected in any bulk supply agreement we enter into with a New Appointee.
- (2) Affinity Water will calculate consumption usage of a NAV by reading the bulk meter installed at the boundary of the site. Affinity Water do not pass the cost of bulk meters onto NAV customers.
- (3) We will charge new appointees for these site-specific works that we undertake at their request. For these purposes, charges for site specific works will be calculated using the same charges as are set for such works under our charging arrangements.
- (4) We will recover infrastructure charges from the New Appointee as a contribution to our costs of network reinforcement. The infrastructure charges will be calculated using the same charges as are set for such works under our charging arrangements.
- (5) Where we enter into a bulk supply agreement with a NAV customer, details of income offset payments will be documented in the bulk supply agreement.

18. WORKED EXAMPLES

- (1) The following worked examples are in line with the recent Ofwat Information Notice 20/07, which specified the worked examples to be included in these charging arrangements.

18.1 EXAMPLE 1 -SINGLE WATER SERVICE CONNECTION

- **Connection to existing mains. This includes service pipe and boundary box fitting, excavation and reinstatement.**
- **25-32mm PE pipe.**
- **Short connection – 4m Surfaced Ground.**
- **Typical traffic management – including any council charges.**

Ref.	Description	Qty	Charges 2021 - 22 (£)	Total 2021-22 (£)
	Traffic Management			
11.1.1	2 Way traffic lights	1	840	840
	Table 9.2: New Connections Application Fees			
9.2.1	Application Fee (first property connected) per application	1	120	120
	Table 9.3: New Connections Administration Fees			
9.3.1	Administration Fee, per property	1	80	80
	Table 9.4: Installation of Connections (MDPE)			
9.4.1	Surfaced Connection, 25-32mm. (includes 2m of pipe)	1	1,250	1,250
9.4.12	Additional Pipework Surfaced (25-32mm).	2	240	480
	Infrastructure Charges			
16.10	Infrastructure Charge per connection	1	249	249
16.7	Deduct income offset per connection	1	-387.26	-387.26
Total (£) Excluding VAT				2,631.74

18.2 EXAMPLE 1A – SINGLE WATER SERVICE CONNECTION

- **Connection to existing mains. This includes service pipe and boundary box fitting, excavation and reinstatement.**
- **25-32mm PE pipe.**
- **Long connection – 8m (4m Surfaced Ground and 4m unmade ground).**
- **Typical traffic management – including any council charges.**

Ref.	Description	Qty	Charges 2021-22 (£)	Total 2021-22 (£)
	Traffic Management			
11.1.1	2 Way traffic lights	1	840	840
	Table 9.2: New Connections Application Fees			
9.2.1	Application Fee (first property connected) per application	1	120	120
	Table 9.3: New Connections Administration Fees			
9.3.1	Administration Fee, per property	1	80	80
	Table 9.4: Installation of Connections (MDPE)			
9.4.1	Surfaced Connection, Per connection Single: (25-32mm) (includes 2m of pipe)	1	1,250	1,250
9.4.12	Surfaced Connection, Per linear metre, Lay Pipe (25-32mm).	2	240	480
9.4.12	Unmade Ground, Per linear metre, Lay Pipe (25-32mm).	4	100	400
	Infrastructure Charges			
16.10	Infrastructure Charge per connection	1	249	249
16.7	Deduct income offset per connection	1	-387.26	-387.26
Total (£) Excluding VAT				3,031.74

18.3 EXAMPLE 2 – WATER SERVICE CONNECTION – DEVELOPMENT OF A NEW BLOCK OF 10 FLATS

- Large diameter water connection (63mm) to an existing main. This includes service pipe and boundary box fitting, excavation and reinstatement.
- Short connection – 4m Surfaced Ground.
- Typical traffic management – including any council charges.

Ref.	Description	Qty	Charges 2021- 22 (£)	Total 2021-22 (£)
	Traffic Management			
11.1.1	2 Way traffic lights	1	840	840
	Table 9.2: New Connections Application Fees			
9.2.1	Application Fee (first property connected) per application	1	120	120
9.2.2	Application Fee (each subsequent property connected) per application	9	30	270
	Table 9.3: New Connections Administration Fees			
9.3.1	Administration Fee, per property	10	80	800
	Table 9.4: Installation of Connections (MDPE)			
9.4.3	Surfaced Connection, per connection Without meter Single: 50-63mm. (includes 2m of pipe)	1	1,650	1,650
9.4.3	Barrier pipe % Uplift, Per connection: (50-63mm)	1	247.50	247.50
9.4.13	Additional Pipework Surfaced, Per linear metre, (50-63mm)	2	250	500
9.4.13	Barrier pipe % Uplift, Per linear metre, (50-63mm)	2	37.50	75
9.4.19	Per property / item, Install Internal 15mm Screw-in Meter.	10	103	1,030
	Infrastructure Charges			
16.10	Infrastructure Charge per connection	10	249	2,490
16.7	Deduct income offset per connection	10	-387.26	-3,872.60
Total Excluding VAT				4,149.90

18.4 EXAMPLE 2A - WATER SERVICE CONNECTION – DEVELOPMENT OF A NEW BLOCK OF 10 FLATS

- Large diameter water connection (63mm) to an existing main. This includes service pipe and boundary box fitting, excavation and reinstatement.
- Long connection – 8m (4m Surfaced Ground and 4m unmade ground).
- Typical traffic management – including any council charges.

Ref	Description	Qty	Charges 2021 - 22 (£)	Total 2021-22 (£)
	Traffic Management			
11.1.1	2 Way traffic lights	1	840	840
	Table 9.2: New Connections Application Fees			
9.2.1	Application Fee (first property connected) per application	1	120	120
9.2.2	Application Fee (each subsequent property connected) per application	9	30	270
	Table 9.3: New Connections Administration Fees			
9.3.1	Administration Fee, per property	10	80	800
	Table 9.4: Installation of Connections (MDPE)			
9.4.3	Surfaced Connection, Per connection Without meter Single: 50-63mm. (includes 2m of pipe)	1	1,650	1,650
9.4.3	Barrier pipe % Uplift: 50-63mm	1	247.50	247.50
9.4.13	Additional Pipework Surfaced, Per linear metre (50-63mm)	2	250	500
9.4.13	Unmade Ground, Per linear metre, (50-63mm)	4	105	420
9.4.13	Barrier pipe % uplift 50-63mm surfaced	2	37.50	75
9.4.13	Barrier pipe % uplift 50-63mm unmade ground	4	15.75	63
9.4.19	Per property / item, Install Internal 15mm Screw-in Meter.	10	103	1,030
	Infrastructure Charges			
16.10	Infrastructure Charge per connection	10	249	2,490
16.7	Deduct income offset per connection	10	-387.26	-3,872.60
	Total (£) Excluding VAT			4,632.90

18.5 EXAMPLE 3 – SMALL HOUSING DEVELOPMENT OF 10 NEW HOMES

- 10 New connections of new mains – 3m unmade ground. This includes service pipe and boundary box fitting, excavation and reinstatement;
- New off-site connection to the existing main, including traffic management charges;
- New mains required – total length 50m, consisting of:
 - 90mm PE – 10m surfaced (leading to the point of connection);
 - 90mm PE – 20m unmade ground;
 - 63mm PE – 20m unmade ground.

Ref.	Description	Qty	Charges 2021 - 22 (£)	Total 2021-22 (£)
Table 8.2: Mains Application Fees				
8.2.1	Application Fee for Mains	1	450	450
Table 8.3: Mains Design Fees				
8.3.1	Design 0-50 properties per scheme / phase	1	750	750
Table 8.4: Mains Administration Fees				
8.4.1	Mains Administration Fee	1	1,000	1,000
Table 8.5: Laying of Water Main				
8.5.1	Surfaced Connection, Per linear metre, Lay Pipe (50-100mm)	10	270	2,700
8.5.1	Unmade Ground, Per linear metre, Lay Pipe (50-100mm)	40	100	4,000
Traffic Management				
11.1.2	3 Way traffic lights	1	926	926
Table 8.7: Connecting Water Main into Supply System (MDPE & Barrier Pipe)				
8.7.1	Surfaced Connection, Under Pressure Connection / Branch Connection (50-190mm diameter pipe) (includes 2m of pipe)	1	1,764	1,764
Table 9.2: New Connections Application Fees				
9.2.3	Application Fee, per property	10	40	400
Table 9.3: New Connections Administration Fees				
9.3.1	Administration Fee, per property	10	80	800
Table 9.4: Installation of Connections (MDPE)				
9.4.1	Unmade Ground, 25-32mm, Per connection	10	584	5,840
9.4.12	Lay Pipe 25-32mm Unmade ground	10	100	1,000
Infrastructure Charges				
16.10	Infrastructure Charges, per connection	10	249	2,490
16.7	Deduct income offset per connection	10	-387.26	-3,872.60
Total (£) Excluding VAT				18,247.40

18.6 EXAMPLE 4 – MEDIUM HOUSING DEVELOPMENT OF 50 NEW HOMES

- 50 new connections off new mains – 3m unmade ground. This includes service pipe and boundary box fitting, excavation and reinstatement;
- New off-site connection to the existing main, including traffic management charges;
- New mains required – total length 300m, consisting of
 - 180mm PE – 10m surfaced (leading to the point of connection);
 - 180mm PE – 90m unmade ground;
 - 125mm PE – 100m unmade ground;
 - 90 PE – 100m unmade ground.

Ref	Description	Qty	Charges 2021 - 22 (£)	Total 2021-22 (£)
Table 8.2: Mains Application Fees				
8.2.2	Application Fee for Mains	1	500	500
Table 8.3: Mains Design Fees				
8.3.2	Design 0-51 properties, per scheme / phase	1	1,000	1,000
Table 8.4: Mains Administration Fees				
8.4.2	Mains Administration Fee	1	1,100	1,100
Table 8.5: Laying of Water Main				
8.5.3	Surfaced Ground, Lay Pipe (131-190mm), Per linear metre	10	350	3,500
8.5.3	Unmade Ground, Lay Pipe (131-190mm), Per linear metre	90	130	11,700
8.5.2	Unmade Ground, Lay Pipe (101-130mm), Per linear metre	100	110	11,000
8.5.1	Unmade Ground, Lay Pipe (50-100mm), Per linear metre	100	100	10,000
Traffic Management				
11.1.2	3 Way traffic lights	1	926	926
Table 8.7: Connecting Water Main into Supply System				
8.7.1	Surfaced Ground, Under Pressure Connection / Branch Connection (50-190mm diameter pipe). (includes 2m of pipe)	1	1,764	1,764
Table 9.2: New Connections Application Fees				
9.2.3	Application Fee, per application	50	40	2,000
Table 9.3: New Connections Administration Fees				
9.3.1	Administration Fee, per property	50	80	4,000
Table 9.4: Installation of Connections (MDPE)				
9.4.1	Unmade Ground, 25-32mm, Per connection, Single:	50	584	29,200
9.4.12	Lay Pipe 25-32mm Unmade ground	50	100	5,000
Infrastructure Charges				
16.10	Infrastructure Charges, Per connection	50	249	12,450
16.7	Deduct income offset per connection	50	-387.26	-19,363.00
Total (£) Excluding VAT				74,777

18.7 EXAMPLE 5 – LARGE HOUSING DEVELOPMENT OF 200 NEW HOMES

- 200 new connections off new mains – 3m unmade ground. This includes service pipe and boundary box fitting, excavation and reinstatement;
- New off-site connection to the existing main, including traffic management charges;
- New main required – total length 1000m
 - 180 PE – 10m made ground (leading to the point of connection);
 - 180mm PE – 290m unmade ground;
 - 125mm PE – 300m unmade ground;
 - 90mm PE – 400m unmade ground.

Ref.	Description	Qty	Charges 2021 - 22 (£)	Total 2021-22 (£)
Table 8.2: Mains Application Fees				
8.2.3	Application Fee for Mains, per application	1	550	550
Table 8.3: Mains Design Fees				
8.3.3	Design 101-200 properties, per scheme / phase	1	1,200	1,200
Table 8.4: Mains Administration Fees				
8.4.1	Mains Administration Fee, per application	1	1,200	1,200
Table 8.5: Laying of Water Mains				
8.5.3	Surfaced Ground, Lay Pipe (131-190mm)	10	350	3,500
8.5.3	Unmade Ground, Lay Pipe (131-190mm)	290	130	37,700
8.5.2	Unmade Ground, Lay Pipe (101-130mm)	300	110	33,000
8.5.1	Unmade Ground, Lay Pipe (80-100mm)	400	100	40,000
Traffic Management				
11.1.2	3 Way traffic lights	1	926	926
Table 8.7: Connecting Water Mains into Supply System (MDPE & Barrier Pipe)				
8.7.1	Surfaced Ground, Under Pressure Connection / Branch Connection (50-190mm diameter pipe) (includes 2m of pipe)	1	1,764	1,764
Table 9.2: New Connections Application Fees				
9.2.3	Application Fee, Per connection	200	40	8,000
Table 9.3: New Connections Administration Fees				
9.3.1	Administration Fee, Per connection	200	80	16,000
Table 9.4: Installation of Connections (MDPE)				
9.4.1	Unmade Ground, 25-32mm, Per connection Single:	200	584	116,800
9.4.12	Lay Pipe 25-32mm Unmade ground	200	100	20,000
Infrastructure Charges,				
16.10	Infrastructure Charges, Per connection	200	249	49,800
16.7	Deduct income offset per connection	200	-387.26	-77,452
Total (£) Excluding VAT				252,988

18.8 EXAMPLE 6 – SELF LAY SMALL DEVELOPMENT

- This example assumes that all contestable activities are undertaken by self-lay providers. This example includes all non-contestable activities and the relevant charges (e.g. infrastructure charge, income offset etc.) and all admin fees and other relevant fees (application, inspection, etc).

Self- Lay Fees					
Ref	Item	Unit	Qty	Charges 2021-22 (£)	Total 2021-22 (£)
6.2: Self-lay water mains Application Fees					
6.2.1	Application Fee for self-lay mains	per application	1	350	350
6.5a: Connection Water Mains into Supply System					
6.5.1	Under Pressure Connection / Branch Connection (50-190mm diameter parent main) (includes 2m of pipe)	per connection	1	1,764	1,764
6.4: Self-lay water mains Administration Fees					
6.4.1	Administration Fee	per application	1	500	500
7.2: Self-lay Service Connections Application Fees					
7.2.1	Application Fee Service Connections, per property	per application	10	20	200
Traffic Management					
11.1.1	2 Way traffic lights	per connection	1	840	840
7.3: Self-lay communication pipes Administration Fees					
7.3.1	Administration Fee	per connection	10	40	400
Infrastructure charges					
16.10	Infrastructure Charge	per application	10	249	2,490
16.7	Deduct income offset per connection	per application	10	-387.26	-3,872.60
Total (£) Excluding VAT					2,671.40

18.9 EXAMPLE 6A – SELF LAY MEDIUM DEVELOPMENT

- This example assumes that all contestable activities are undertaken by self-lay providers. This example includes all non-contestable activities and the relevant charges (e.g. infrastructure charge, income offset etc.) and all admin fees and other relevant fees (application, inspection, etc).

Self- Lay Fees					
Ref	Item	Unit	Qty	Charges 2021-22 (£)	Total 2021-22 (£)
6.2: Self-lay water mains Application Fees					
6.2.1	Application Fee for self-lay mains	per application	1	400	400
6.5a: Connection Water Mains into Supply System					
6.5.1	Under Pressure Connection / Branch Connection (50-190mm diameter parent main) (includes 2m of pipe)	per connection	1	1,764	1,764
6.4: Self-lay water mains Administration Fees					
6.4.2	Administration Fee	per application	1	550	550
6.4.4	Site Visit	per application	2	102	204
7.2: Self-Lay Services Connections Application Fees					
7.2.1	Application Fee Service Connections, per property	per application	50	20	1,000
Traffic Management					
11.1.2	3 Way traffic lights	per connection	1	926	926
7.3: Self-lay communication pipes Administration Fees					
7.3.1	Administration Fee	per connection	50	40	2,000
Infrastructure charges					
16.10	Infrastructure Charge	per application	50	249	12,450
16.7	Deduct income offset per connection	per application	50	-387.26	-19,363
Total (£) Excluding VAT					-69

18.10 EXAMPLE 6B – SELF LAY LARGE DEVELOPMENT

- This example assumes that all contestable activities are undertaken by self-lay providers. This example includes all non-contestable activities and the relevant charges (e.g. infrastructure charge, income offset etc.) and all admin fees and other relevant fees (application, inspection, etc).

Self- Lay Fees					
Ref	Item	Unit	Qty	Charges 2021- 22 (£)	Total 2021-22 (£)
6.2: Self-lay water mains Application Fees					
6.2.3	Application Fee for self-lay mains	per application	1	450	450
6.5a: Connection Water Mains into Supply System					
6.5.1	Under Pressure Connection / Branch Connection (50-190mm diameter parent main) (includes 2m of pipe)	per connection	1	1,764	1,764
6.4: Self-lay water mains Administration Fees					
6.4.3	Administration Fee	per application	1	600	600
6.4.4	Site Visit	per application	4	102	408
7.2: Self-lay Service Connections Application Fees					
7.2.1	Application Fee Service Connections, per property	per application	200	20	4,000
Traffic Management					
11.1.2	3 Way traffic lights	per connection	1	926	926
7.3: Self-lay communication pipes Administration Fees					
7.3.1	Administration Fee	per connection	200	40	8,000
Infrastructure charges					
16.10	Infrastructure Charge	per application	200	249	49,800
16.7	Deduct income offset per connection	per application	200	-387.26	-77,452
Total (£) Excluding VAT					-11,504

19. CONTACT INFORMATION AND REDRESS

- (1) Any enquiries about these charging arrangements should be addressed to the Company Secretary, Affinity Water Limited, Tamblin Way, Hatfield, Hertfordshire, AL10 9EZ, or via email at ds@affinitywater.co.uk
- (2) We publish a range of information on our website about getting your development connected to water services. By using our website, you can access our portal interface for developer customers who wish to apply for new connections services.
- (3) Our website also contains many useful features to help you with any queries you may have about getting your development connected - <https://www.affinitywater.co.uk/developing>, or you can get in touch with us through the following:



Give us a call

Developer Enquiries	0345 357 2428	Mon-Fri 8.30am-5pm
New Properties Team	0345 307 3437	Mon-Fri 8.30am-4pm
Operations Enquiries	0345 357 2407	Mon-Fri 7am-8pm, Sat-Sun 8am-4pm (Emergency service operated outside these hours)



Website www.affinitywater.co.uk/developing

Email ds@affinitywater.co.uk

Chat <https://affinitywater.custhelp.com>



Write to us Developer Services, Affinity Water,
Tamblin Way, Hatfield, Hertfordshire, AL10 9EZ

- (4) We will always do our best to answer your query fully at our first opportunity, however should you wish to speak to our management team or escalate a query, you can find their contact information here: <https://www.affinitywater.co.uk/developing/contact-developer>
- (5) If you are dissatisfied with the level of service provided and wish to make a complaint, we operate a complaints procedure. We aim to answer all written complaints within 10 working days. Further information and a copy of the procedure are available from our website and on request.
- (6) You may ask the Consumer Council for Water (“CCW”), the independent voice for water consumers in England and Wales, to take up your complaint on your behalf, if we have been unable to resolve your complaint directly with you.
- (7) If your complaint is not resolved to your satisfaction after intervention from CCW, you may be able to use the Water Redress Scheme (WATRS) to ask an independent adjudicator to adjudicate any dispute. The service is free to use. You will not be able to use the scheme to determine a dispute about matters over which Ofwat has powers to determine an outcome.
- (8) Contact information for CCW, Ofwat and WATRS is provided below.

	Consumer Council for Water	Ofwat	WATRS
Address	Consumer Council for Water 1 st Floor Victoria Square House Victoria Square Birmingham B2 4AJ	Water Services Regulation Authority (Ofwat) Centre City Tower 7 Hill Street Birmingham B5 4UA	Water Redress Scheme 70 Fleet Street London EC4Y 1EU
Telephone	0300 034 2222	0121 644 7500	0207 520 3801
Web	www.ccwater.org.uk	www.ofwat.gov.uk	www.watrs.org
Email	enquiries@ccwater.org.uk	mailbox@ofwat.gov.uk	applications@watrs.org